

# TP20 touch trigger probe system

## Kinematic probe system with module changing

The TP20 touch trigger probe enables manual or automatic stylus changing without re-qualification. This allows complex part measurement, where a range of stylus configurations is needed to access all features on the part.

Modules offering a range of trigger forces allow the probe performance to be accurately matched to the measurement task. A set of probe extensions is also available, as is a 6-way module, allowing the inspection of features with restricted access.

The TP20 can be used on a wide range of Renishaw's manual or motorised probe heads, either by direct mounting using the standard M8 thread or alternatively, by using a PAA adaptor to connect with the autojoint on the head.

The optional MCR20 module changing rack can store up to six probe modules for automatic changing under measurement program control. The probe is automatically disabled during the change cycle.

The MSR1 can store up to 6 probe modules for manual stylus changing and safekeeping when not in use.

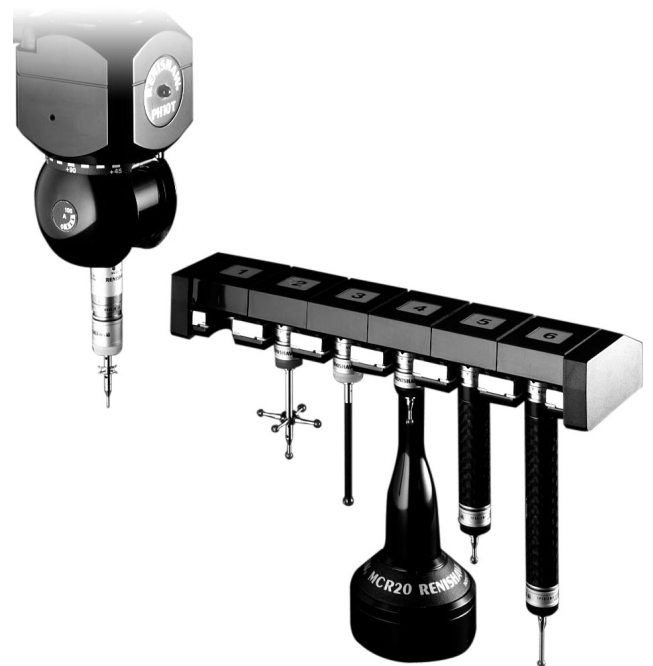

## Key benefits

### Reduced cycle times

Reduced cycle times are achieved through fast stylus changing without re-qualification.

### Optimised probe and stylus performance

Probe and stylus performance are optimised with seven specialised probe modules.

### Industry standard metrology performance

The TP20 brings a range of new benefits over the TP2 probe to both manual and DCC CMMs and can easily be retrofitted to existing TP2 installations.

## Innovations

### Highly repeatable magnetic coupling between probe module and probe body

This enables the exchange of modules without the need to re-qualify the stylus tip giving significant time savings.

### Standard M8 screw connector in the probe body

This offers direct fitting to all CMMs with a Renishaw PH1, MH8 or PH10T probe head. Fitment to PH10M and MIH is simply achieved with a PAA probe adaptor.

### Crash protection

TP20 modules have overtravel in all directions. The magnetic mounting provides additional crash protection in X and Y.

## Specification

<b>Probe body mounting</b>	M8 connector
<b>Suitable interface</b>	Standard touch trigger interface
<b>Sense directions</b>	$\pm X, \pm Y, +Z; \pm X, \pm Y, \pm Z$ (6W only)
<b>Unidirectional repeatability (maximum mean <math>2\sigma</math> at stylus tip)</b>	
LF	0.35 $\mu\text{m}$ (0.000014 in)
SF / EM1 / EM2	0.35 $\mu\text{m}$ (0.000014 in)
MF	0.50 $\mu\text{m}$ (0.00002 in)
EF	0.65 $\mu\text{m}$ (0.000026 in)
6 W	0.80 $\mu\text{m}$ (0.000032 in)
<b>Pretravel variation (XY plane)</b>	
LF	$\pm 0.60 \mu\text{m}$ ( $\pm 0.000023$ in)
SF / EM1 / EM2	$\pm 0.80 \mu\text{m}$ ( $\pm 0.000032$ in)
MF	$\pm 1.00 \mu\text{m}$ ( $\pm 0.000039$ in)
EF	$\pm 2.00 \mu\text{m}$ ( $\pm 0.000079$ in)
6 W	$\pm 1.50 \mu\text{m}$ ( $\pm 0.000058$ in)
<b>Weight (probe and module)</b>	22 g (0.8 oz)
<b>Trigger force</b>	<b>XY plane</b> <b>Z axis</b>
LF	0.055 N      0.65 N
SF / EM1 / EM2	0.08 N      0.75 N
MF	0.1 N      1.9 N
EF	0.1 N      3.2 N
6 W	0.14 N      1.6 N
<b>Overtravel force</b>	<b>XY plane</b> <b>Z axis</b>
LF	0.09 N      1.15 N
SF / EM1 / EM2	0.2-0.3 N      3.5 N
MF	0.2-0.4 N      7.0 N
EF	0.2-0.5 N      10.0 N
6 W	0.25 N      2.5 N
<b>Maximum extension on PH10 series</b>	300 mm (11.81 in)
<b>Change rack system</b>	MCR20/MSR1
<b>Stylus range</b>	M2

### Available modules:

LF = low force (green cap)	Suited to applications that require a low trigger force.
SF = standard force (SF, EM1 and EM2) (black cap)	Suited to a majority of applications.
MF = medium force (grey cap)	For use when a higher trigger force higher than 'SF' is required.
EF = extended force (brown cap)	Required with large stylus assemblies. Also, to eliminate spurious triggers due to machine vibration and acceleration.
6 W = 6-way probe (blue cap)	Designed to measure in the Z- direction.

## Additional information

Renishaw also provide a non-inhibit version of TP20. This requires the probe to be turned off, via application software, when module changing.

For further details on these and other related products, please see [www.renishaw.com/TP20](http://www.renishaw.com/TP20).

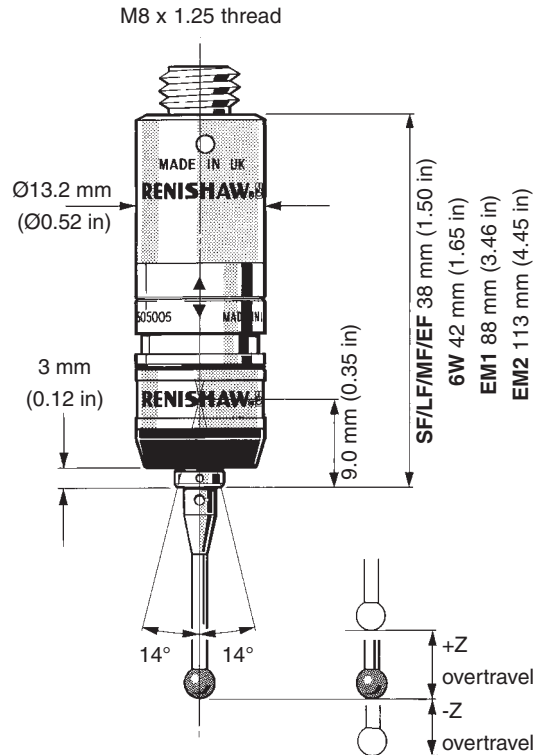

### +Z overtravel

SF/EM1/EM2	4.0 mm (0.16 in)
LF	3.1 mm (0.12 in)
MF	3.7 mm (0.15 in)
EF	2.4 mm (0.09 in)
6W	4.5 mm (0.177 in)

### -Z overtravel

6W	1.5 mm (0.06 in)
----	------------------



For worldwide contact details, please visit our main website at [www.renishaw.com/contact](http://www.renishaw.com/contact)